



PFEIFFER  VACUUM

HiScroll[®]

Vacuum Pump

HiScroll 6

HiScroll 12

Quiet
Efficient
Oil-Free
Compact



HIGHLIGHTS ★

HiScroll

HiScroll pumps are available in two sizes with 6.1 m³/h and 12.1 m³/h pumping speed.

Our pumps are 15% more efficient than comparable products, offering significant operation cost savings whilst also offering the highest performance on the market.

Our pumps are characterized by their pumping speed when evacuating against atmosphere.

Whisper Quiet

HiScroll pumps are extremely quiet at <47 dB(A) and <42 dB(A) in stand-by mode. Their low-vibration operation and compact design make them ideal for use in quiet working environments.

High Process Safety

For safe use, the hermetically sealed HiScroll features a check valve.

High Water Vapour Tolerance

The two stage gas ballast valve ensures high water vapour compatibility which is key for freeze drying.

Quality

The proven quality of Pfeiffer Vacuum products assures a long service life, market leading service interval and lowest cost of ownership..

Best Energy Efficiency

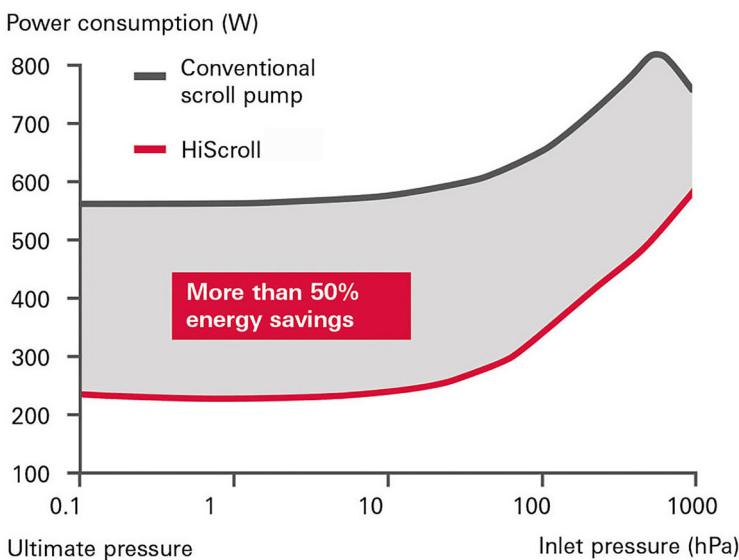

Pumping Curve

HiScroll 6

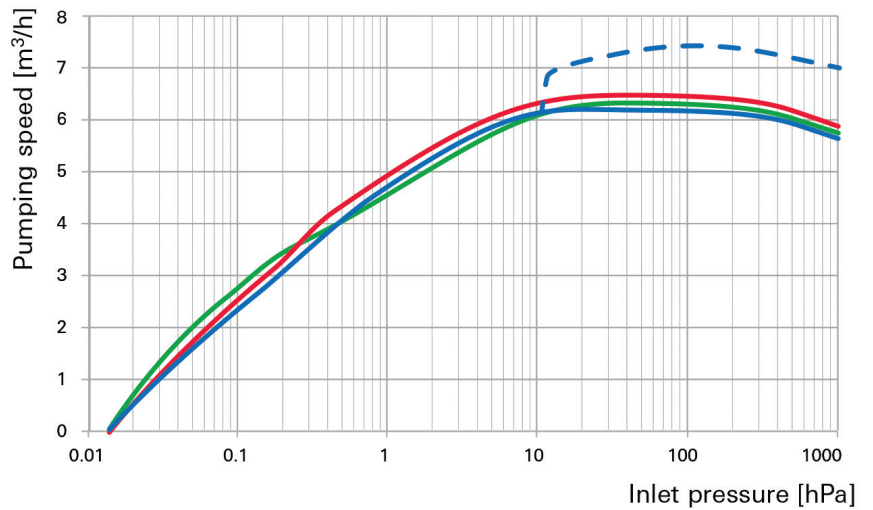

HiScroll 12

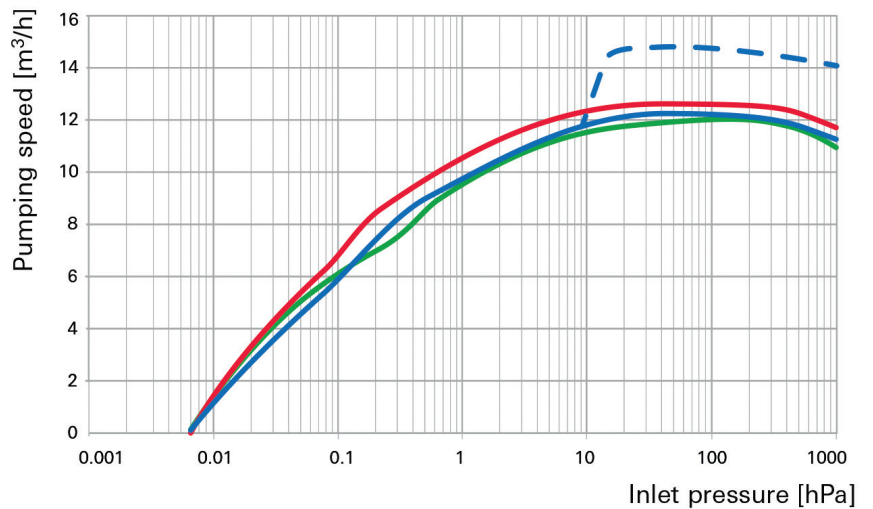

DIMENSIONS



HiScroll 6
D: 380 x W: 220 x H: 279 mm

HiScroll 12
D: 419 x W: 265 x H: 322 mm



HiScroll 6

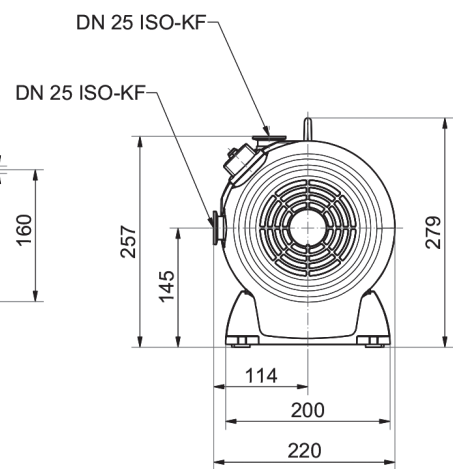
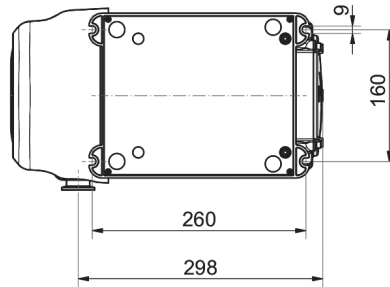
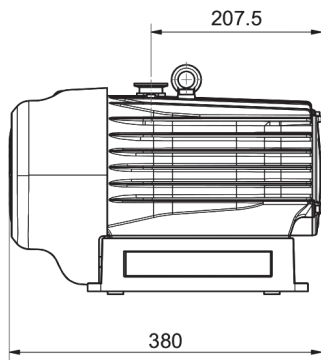

HiScroll 12

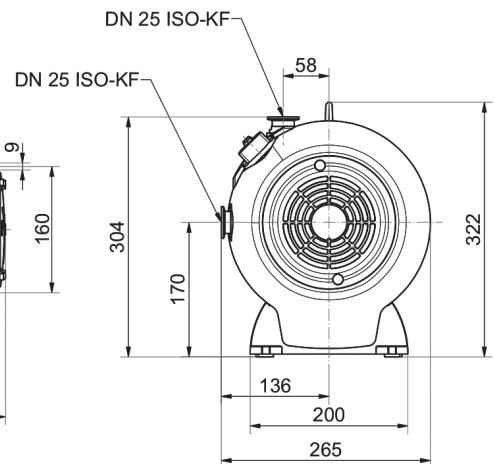
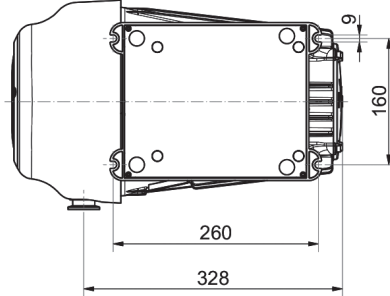
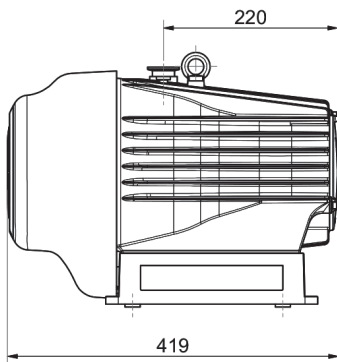

SPECIFICATIONS

	HiScroll 6	HiScroll 12
Pumping Speed	6.1 m ³ /h	12.1 m ³ /h
Ultimate Vacuum	0.015 mbar	0.006 mbar
Power	100 – 127 / 200 – 240 V AC (±10 %), 50/60 Hz	
Dimensions D x W x H	380 x 220 x 279 mm	419 x 265 x 322 mm
Noise Level dB(A)	<48	<47
Inlet Flange	DN 25 ISO-KF	
Weight (kg)	19	24
Operating Temperature	5 – 40 °C	
Certification	CE / UL	

